

# GENUA komoda

Ⓓ **Montageanleitung**

Ⓐ **Handleiding voor de montage**

Ⓙ **Montaj talimatı**

Ⓕ **Notice de montage**

Ⓒ **Montážní návod**

Ⓗ **Szerelési útmutató**

Ⓖ **Assembly Instructions**

Ⓟ **Instrukcja montażu**

Ⓡ **Инструкция по монтажу**

Ⓡ **Istruzioni di montaggio**

Ⓚ **Návod na montáž**

Ⓡ **Instrucțiunile de montaj**

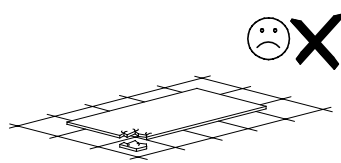
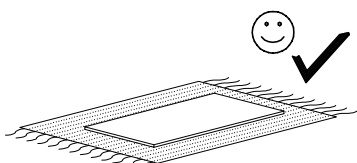
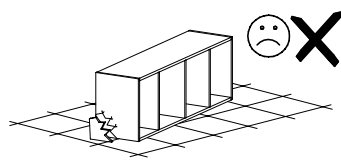
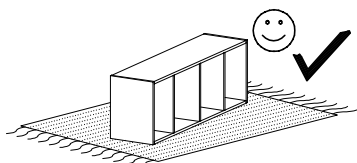
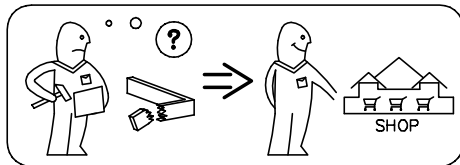
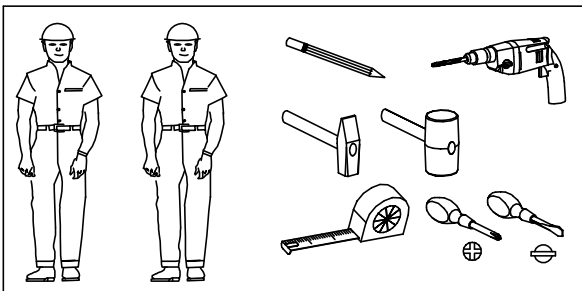
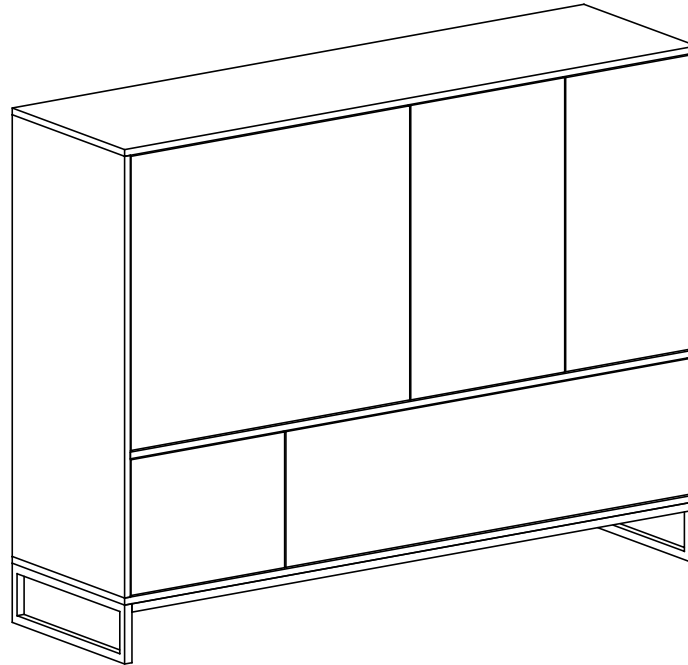

**Uwaga – Upozornini – Achtung – Attention – Caution – Figyelem  
Attenzione – Opgelet – Внимание – Atentie – Upozornenie – Dikkat**

PL	Czyszczenie należy wykonać wyłącznie za pomocą ściereczki lub lekko nawilżonego ręcznika. Nie stosować środków czyszczących do szorowania.
CZ	Čistění je nutné vykonávat výhradně pomoci utěrky nebo lehce navlhčeného ručniku. Nepoužívejte čističí prostředky obsahující abrazivní částice.
D	Bitte nur mit einem Staubtuch oder leicht feuchtem Lappen reinigen. Keine scheuernden Putzmittel verwenden.
GB	Please only clean with duster or damp cloth. Do not use any abrasive cleaners.
F	Le nettoyage se fait uniquement à l'aide d'un torchon ou d'une serviette légèrement mouillée.
HU	A tisztítás kizárólag törleruha vagy enyhén nedvesített törölköző segítségével végezhető. Súroló hatású tisztítószerket nem szabad használni.
I	Pulire esclusivamente con un panno o un asciugamano umido.
NL	Reinig allen met een stofdoek of een lichtjes vochtige doek. Gebruik geen schurende poetsmiddelen.
RU	Очищайте от пыли тряпкой или слегка влажной ветошью. Не допускаются применение чистящих средств, не пред-назначенных для ухода за мебелью.
RO	Curabare trebuie efectuată numai cu o cârpă sau cu un prosop usor umzeit. Nu utilizati agenți de curabare abrazivi.
SK	Čistení je nutné vykonávat výhradne pomoci utierky nebo ľahko zvlhnutým ručnikom. Nepoužívajte čistiaci prostriedky obsahujúci abrazívni častice.
TR	Lütfen sadece bir toz bezile veya hafif nemli yumusak bir bezle siliniz. Asindirici temizlik malzemeleri kullanmayiniz.

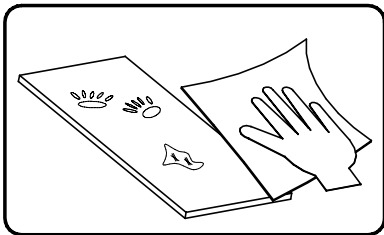
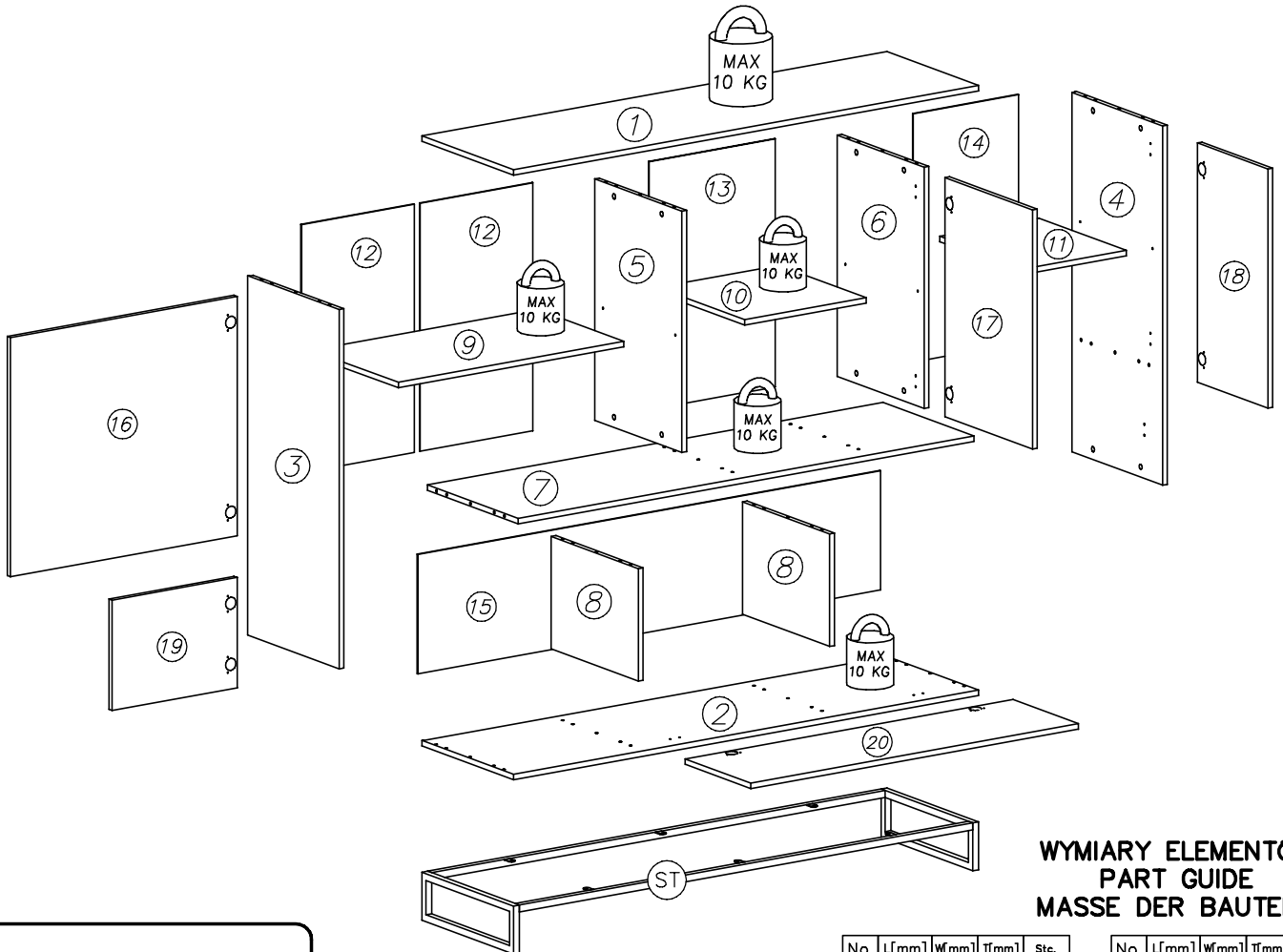
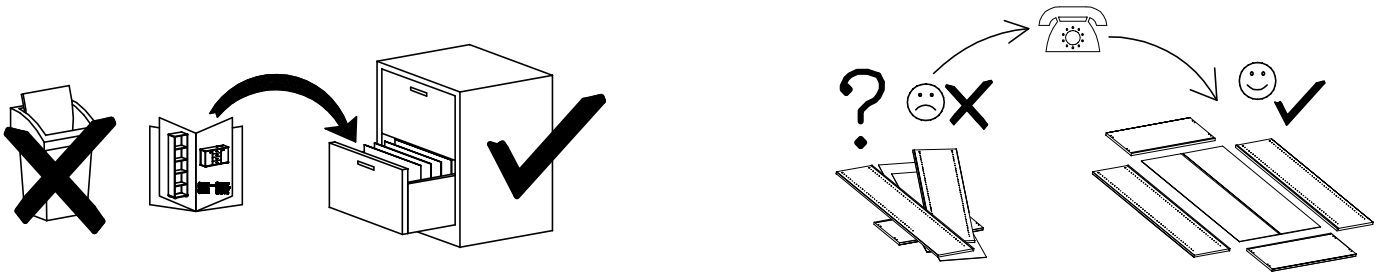



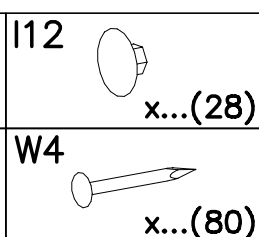
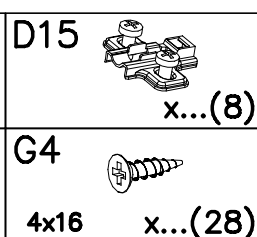
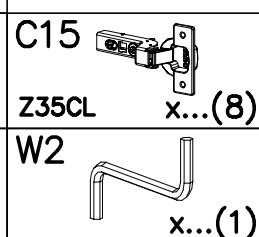
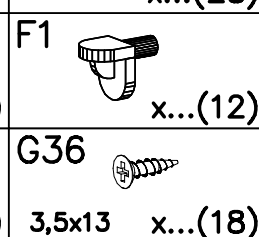
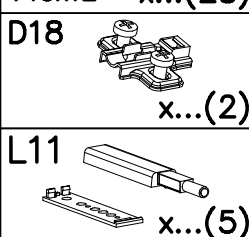
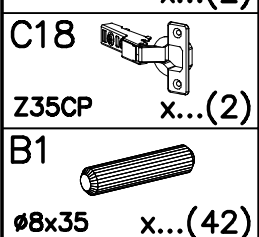
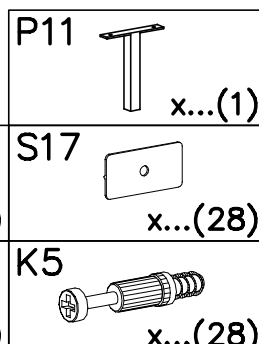
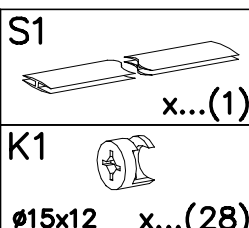
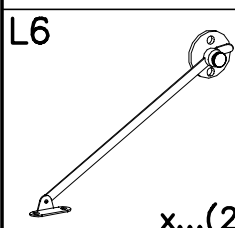
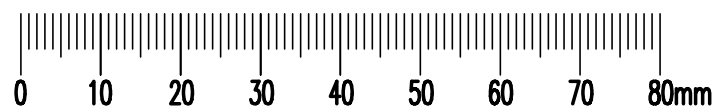

WYMIARY ELEMENTÓW  
 PART GUIDE  
 MASSE DER BAUTEILE

No.	L[mm]	W[mm]	T[mm]	Stc.
1	450	1600	16	1
2	450	1600	16	1
3	450	1048	16	1
4	450	1048	16	1
5	704	428	16	1
6	704	428	16	1
7	446	1568	16	1
8	328	428	16	2
9	428	776	16	1
10	428	418	16	1

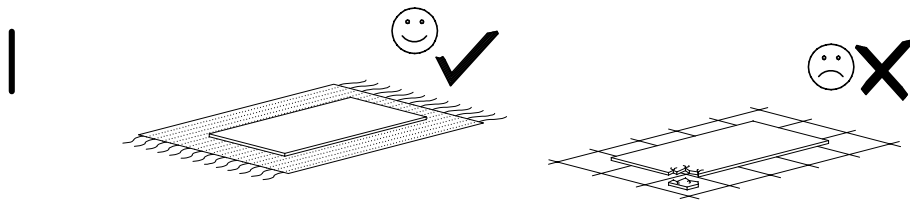
No.	L[mm]	W[mm]	T[mm]	Stc.
11	428	342	16	1
12	722	395	2,5	2
13	722	433	2,5	1
14	722	358	2,5	1
15	345	1587	2,5	1
16	698	780	16	1
17	698	430	16	1
18	698	346	16	1
19	322	430	16	1
20	322	1128	16	1

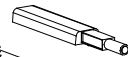

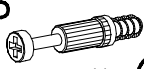
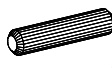

L11  x...(5)	K1  Ø15x12 x...(16)
G36  3,5x13 x...(10)	K5  x...(14)
B1  Ø8x35 x...(30)	D18  PZ35CP x...(2)

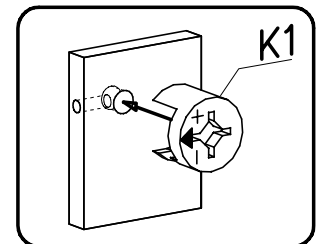
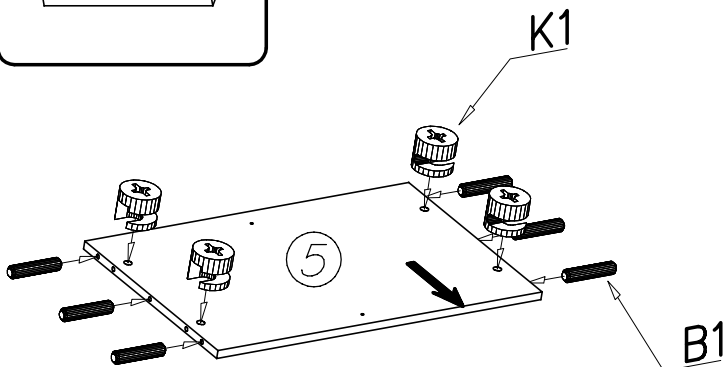
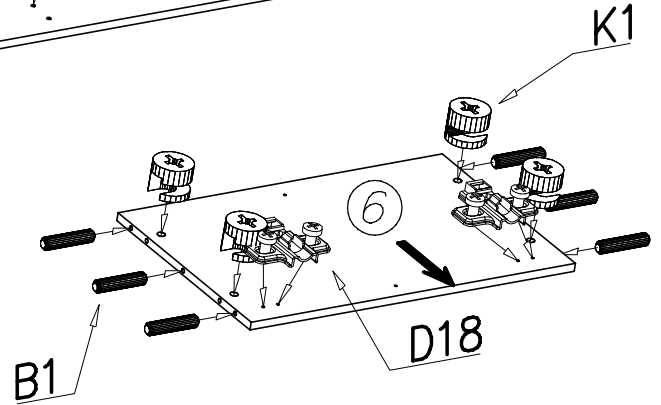
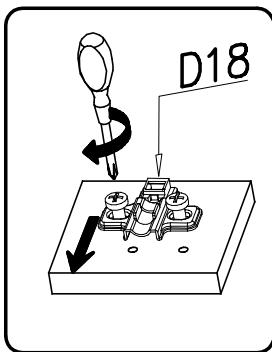
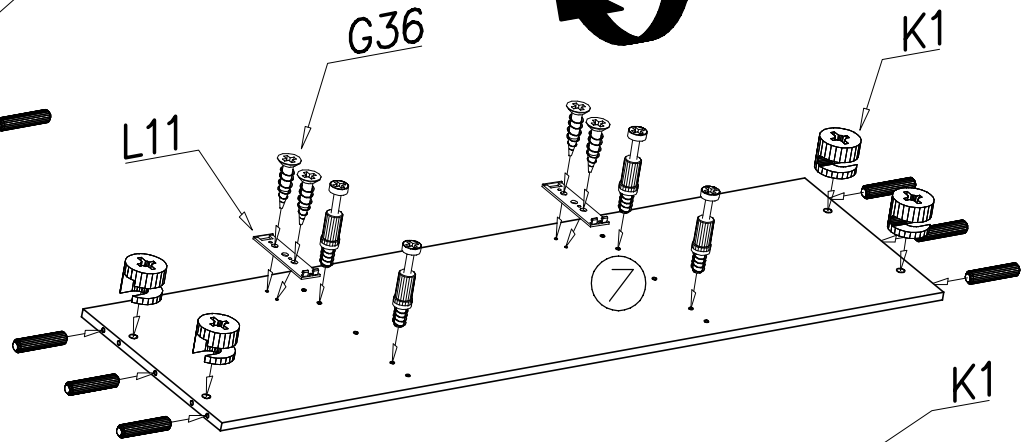
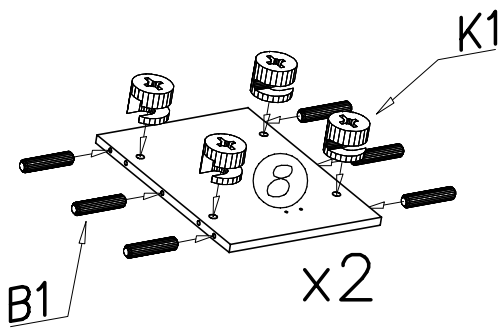
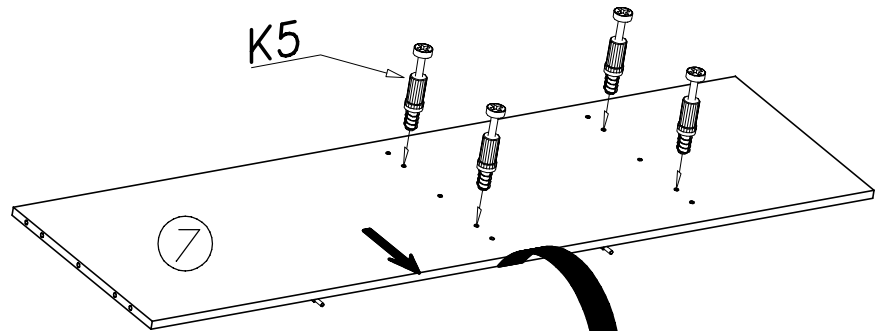
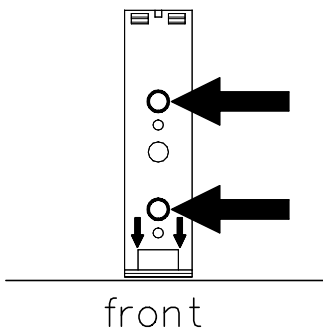
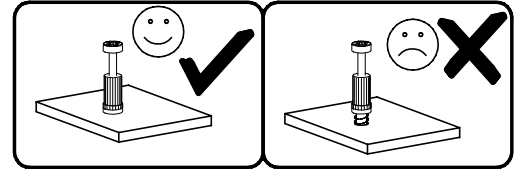
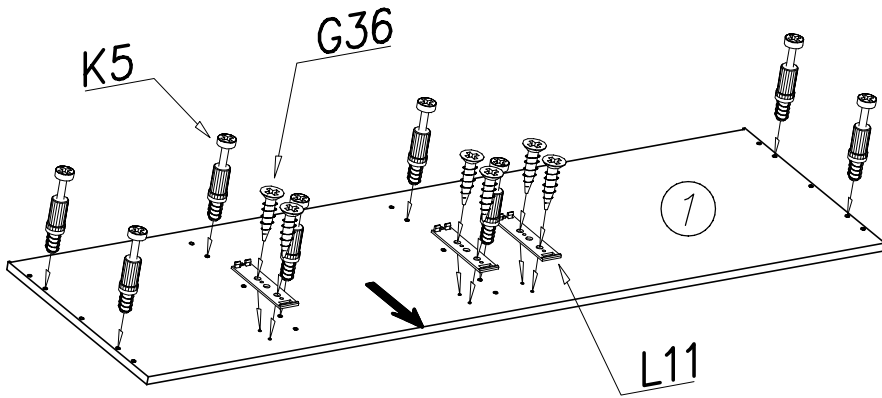

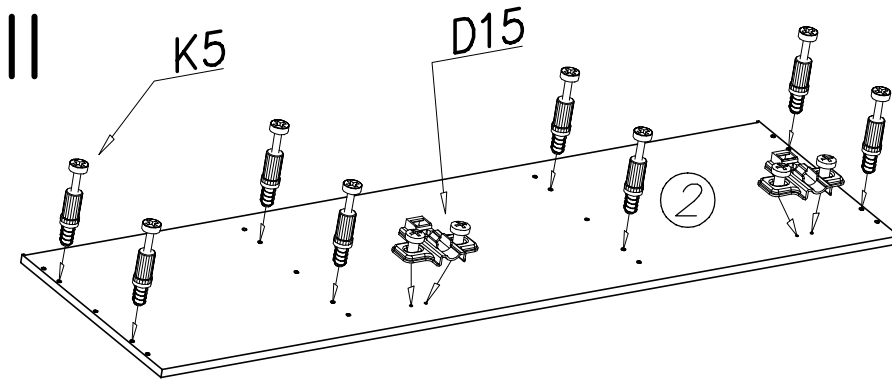

D15		x...(2)	K1		ø15x12	x...(8)
B1		ø8x35	x...(12)	K5		x...(12)

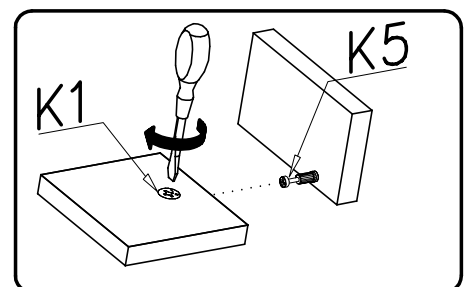
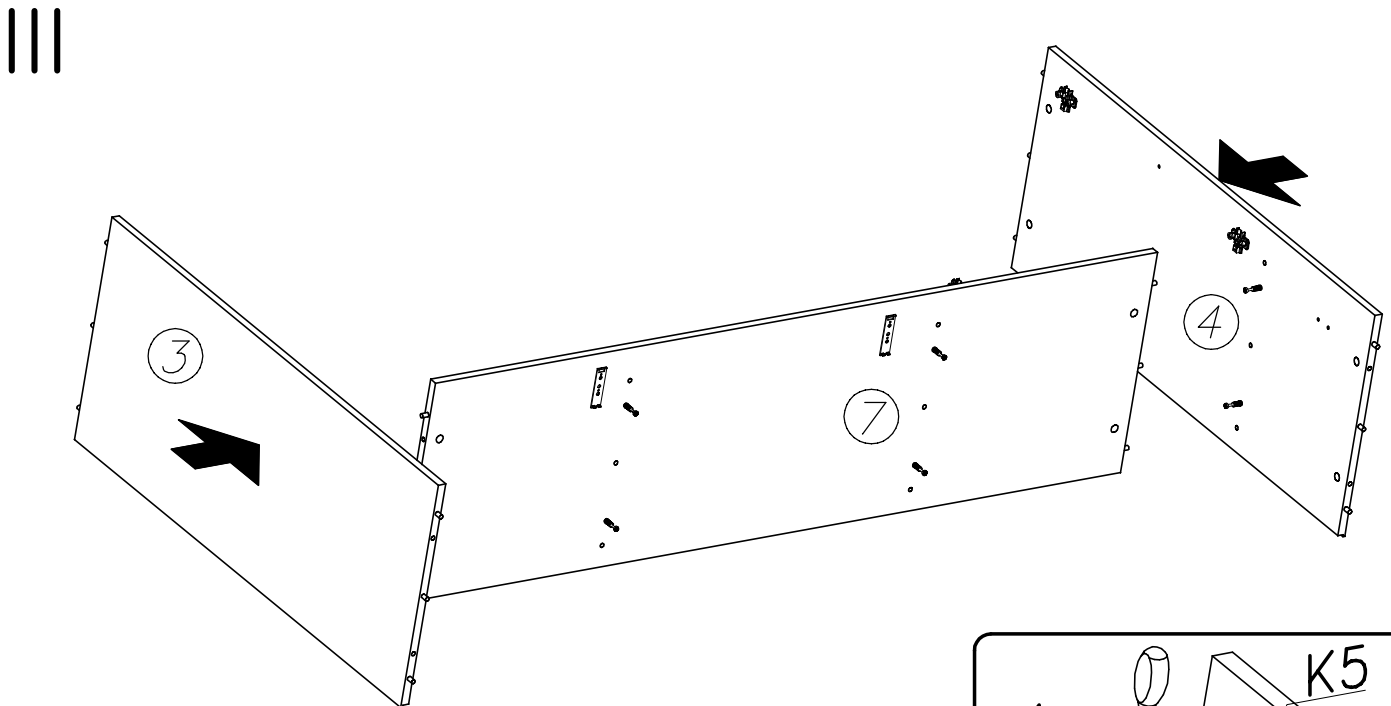
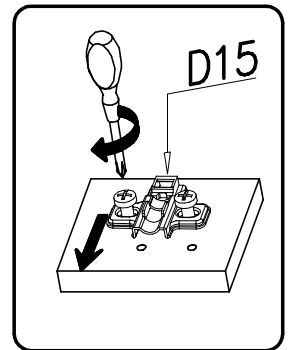
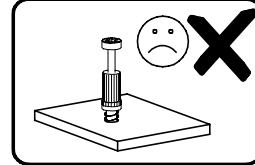
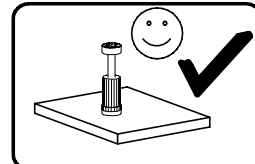
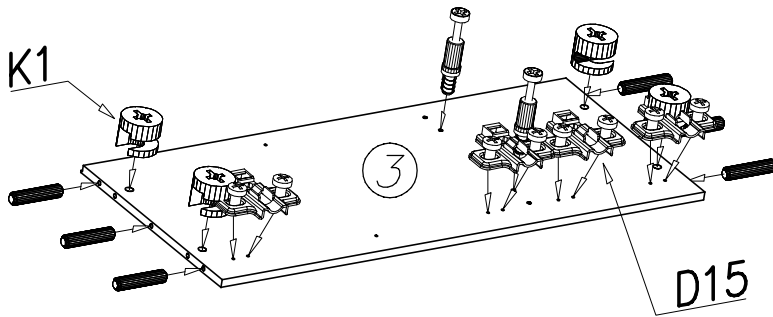
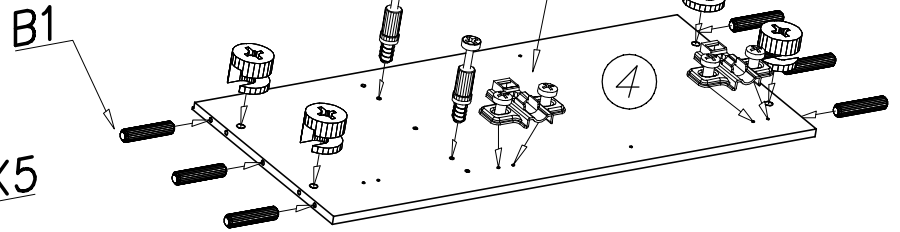
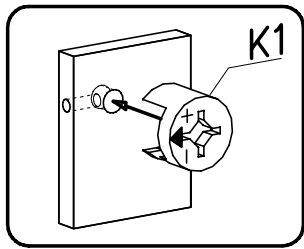

# IV

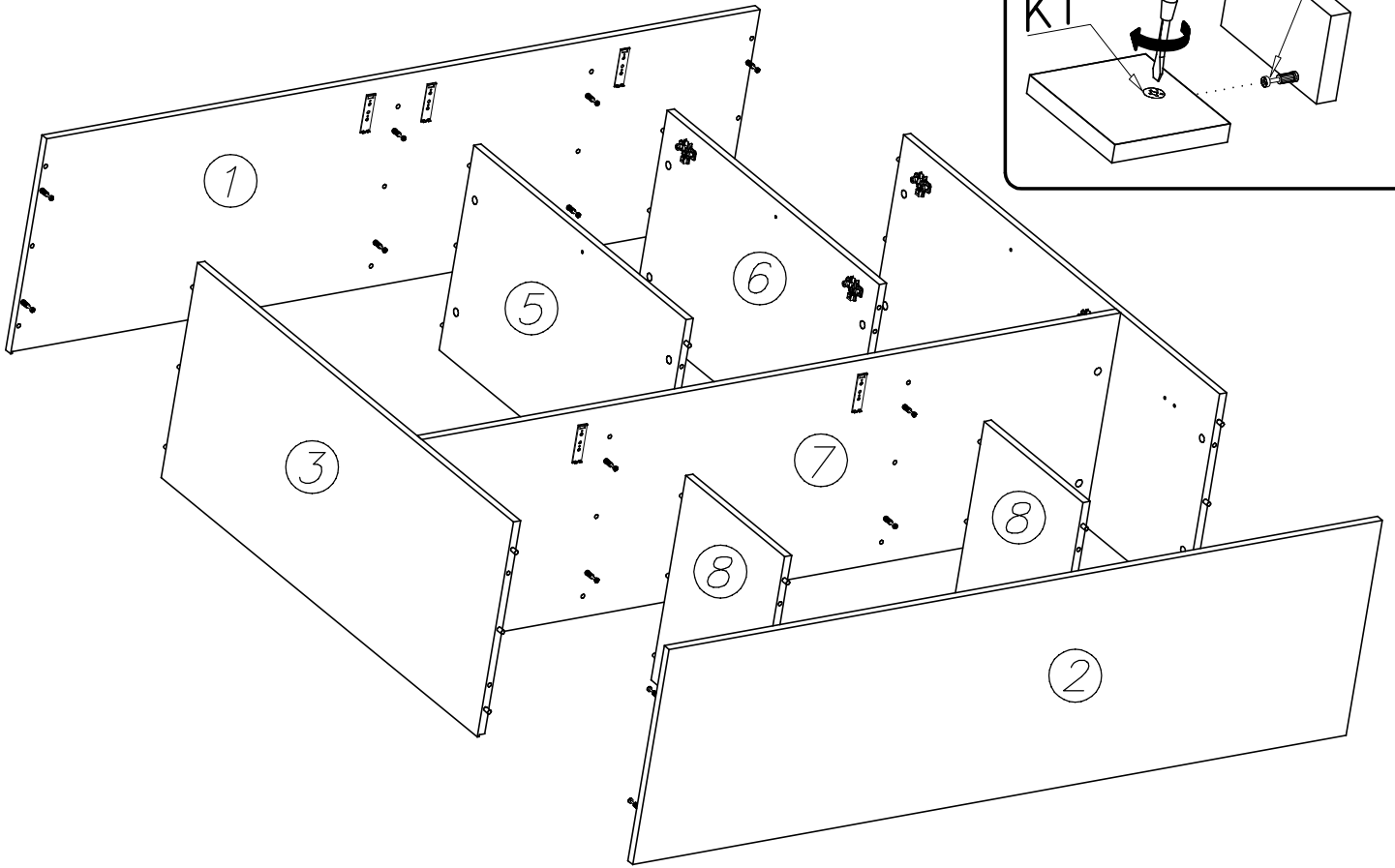

# V

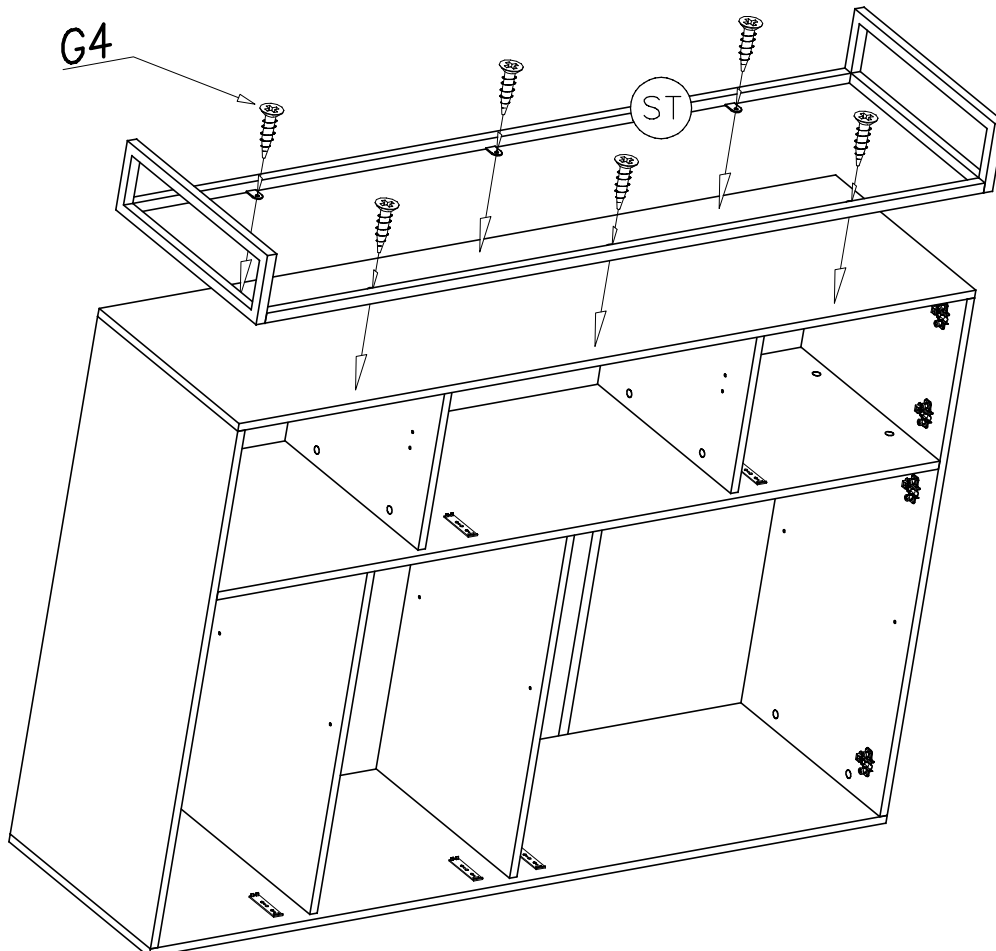



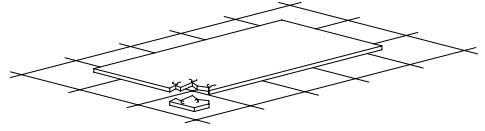
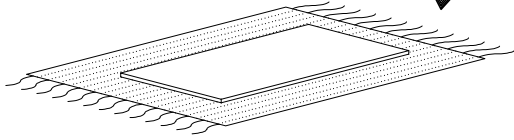

G4  
4x16 x...(6)

VI

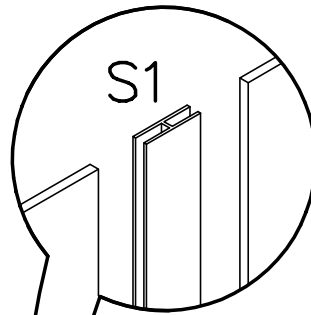
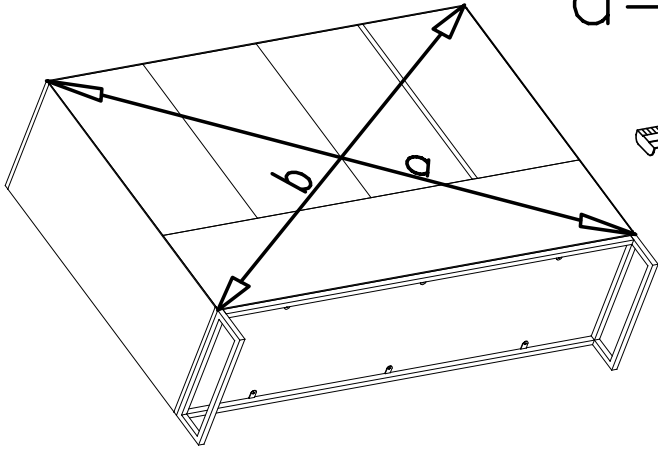
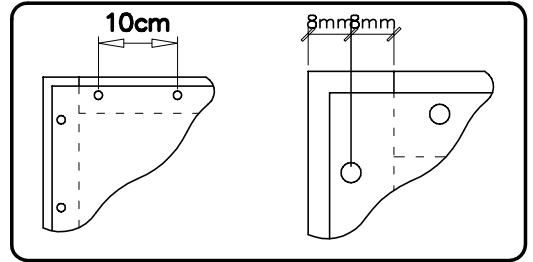
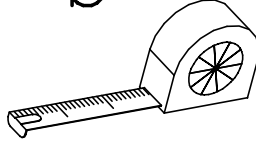

$a = b$



- W4  x...(80)
- S1  x...(1)
- S17  x...(28)

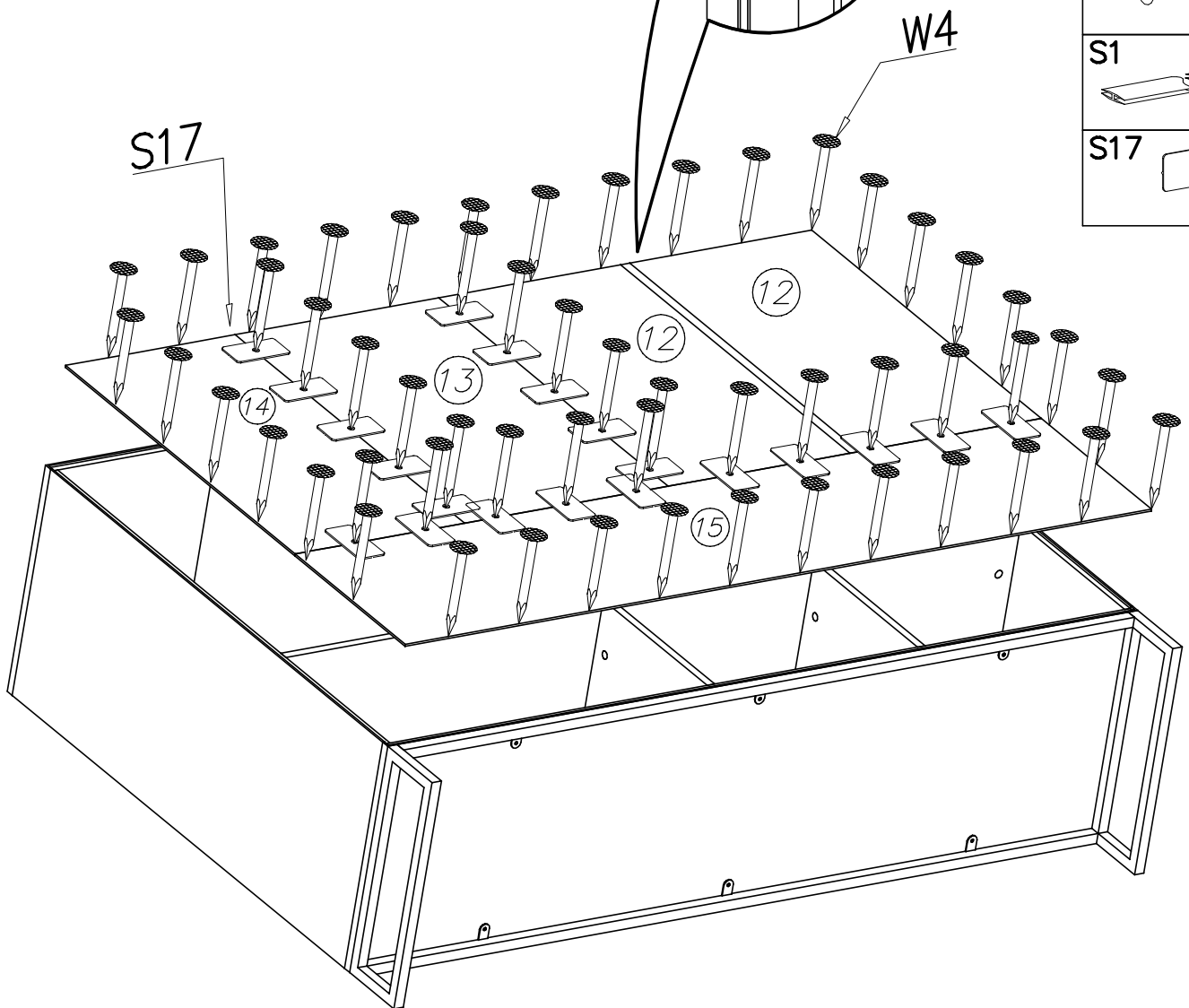

# VII

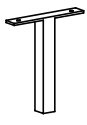
P11  x...(1)

G4  4x16 x...(2)

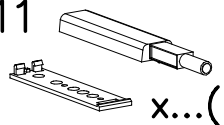
L11  x...(5)

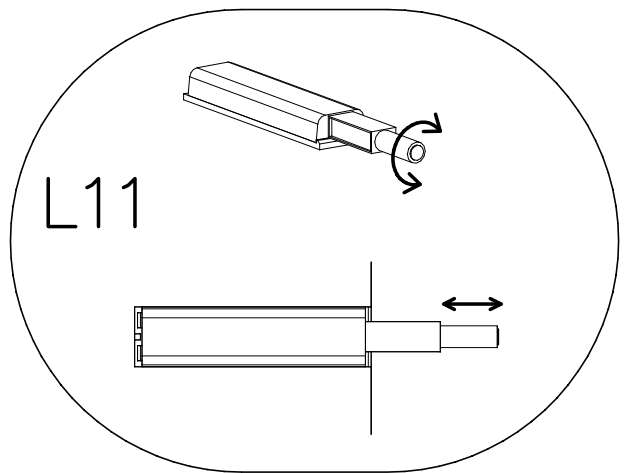
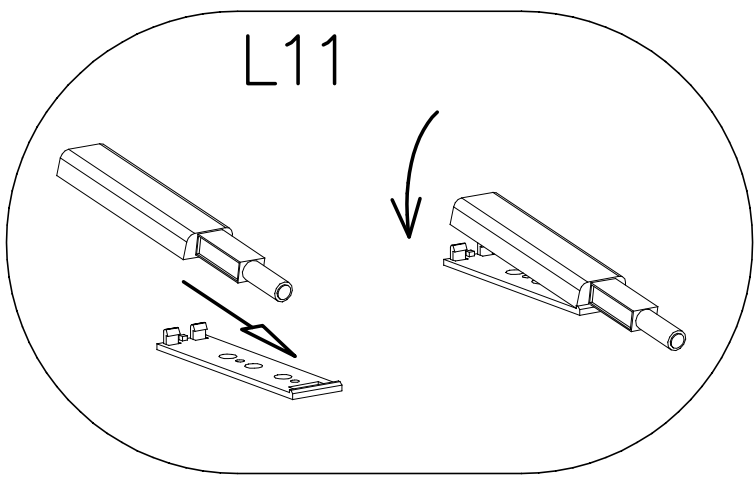
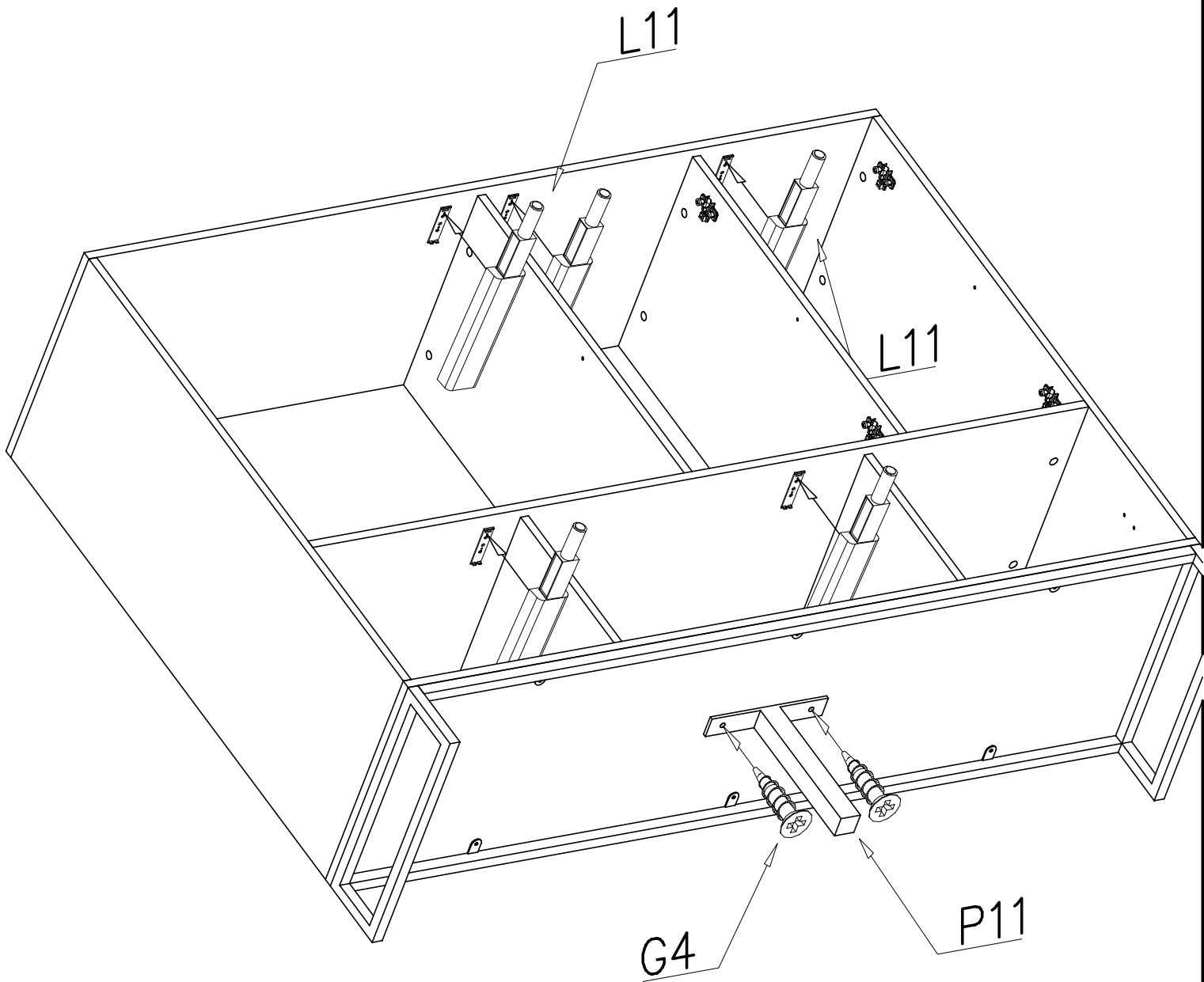

# VIII

F1

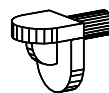

x...(12)

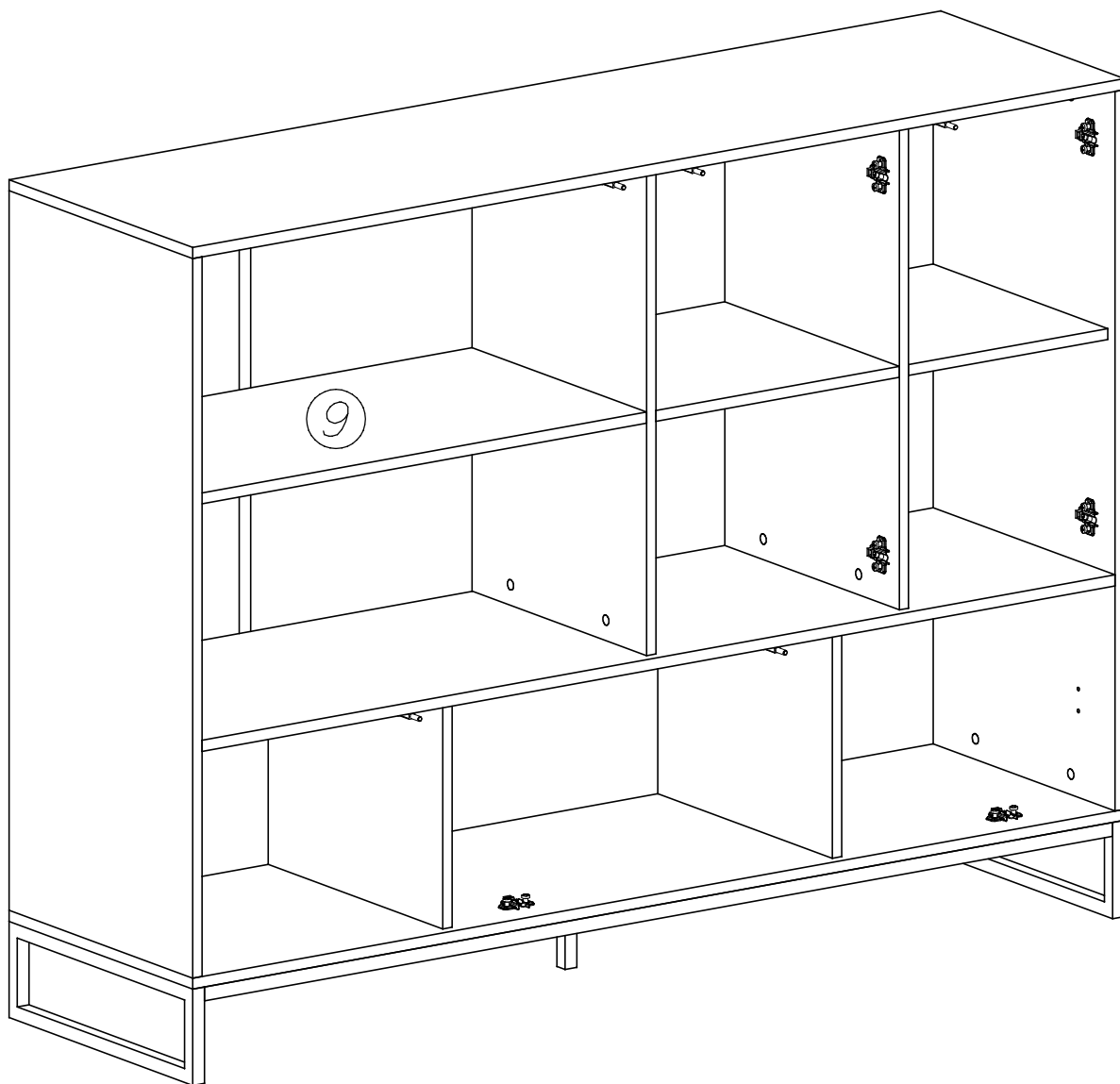

1

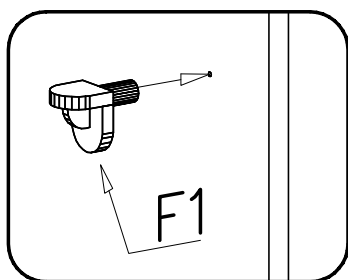

2

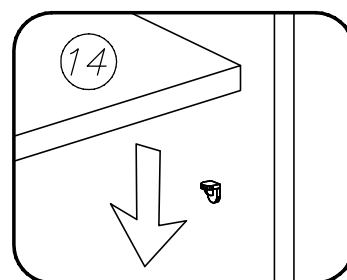

# IX

C15

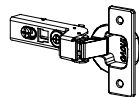

Z35CL

x...(8)

G4



4x16

x...(16)

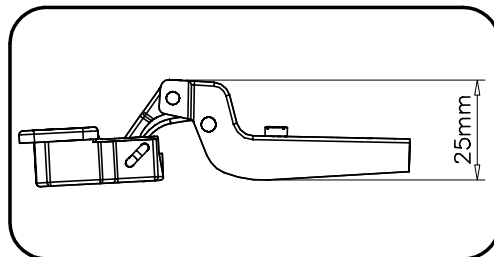
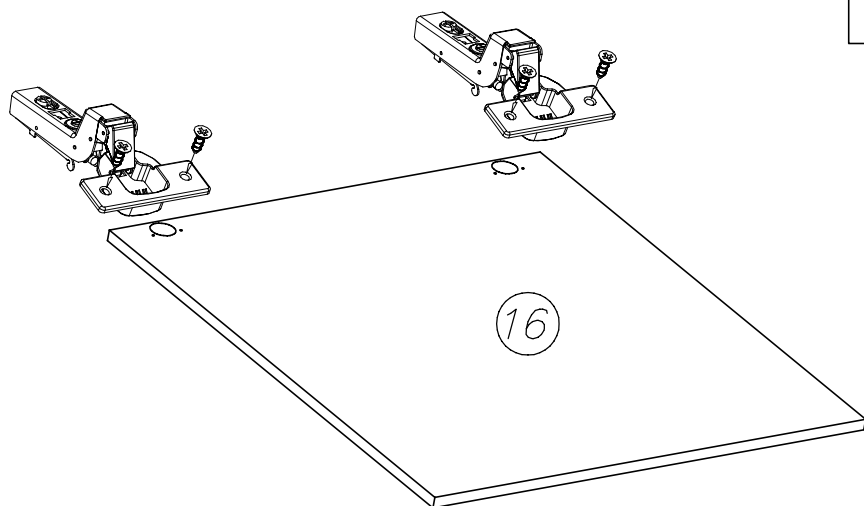

C15

G4

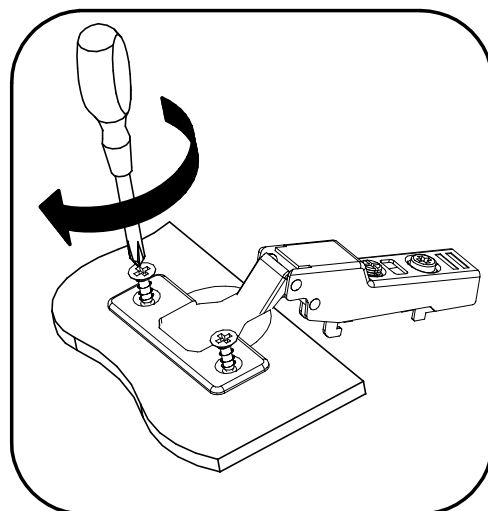
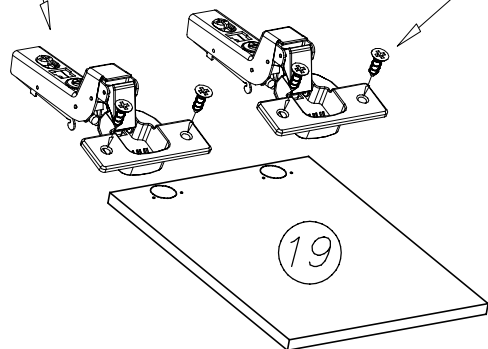

G4

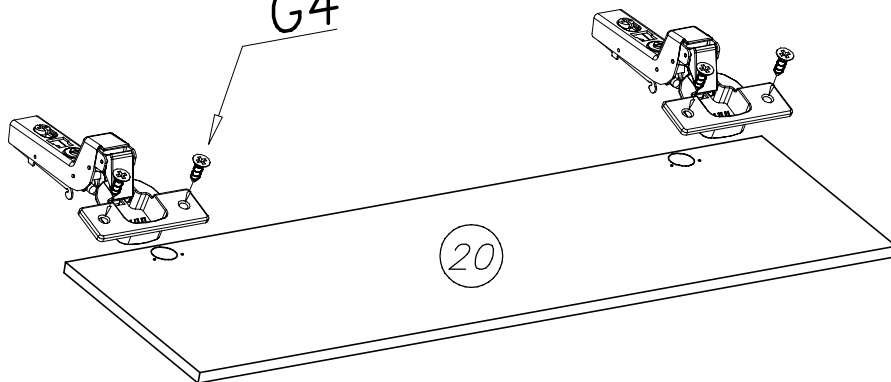

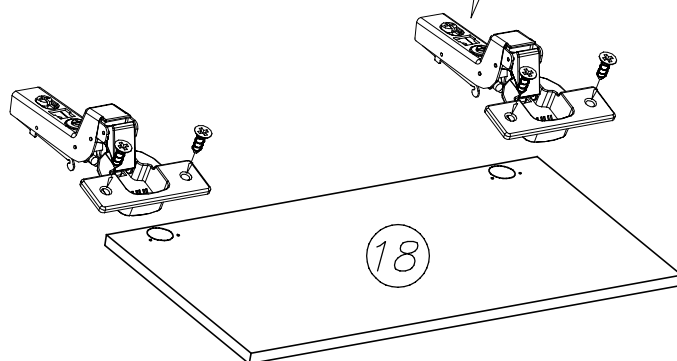

C15

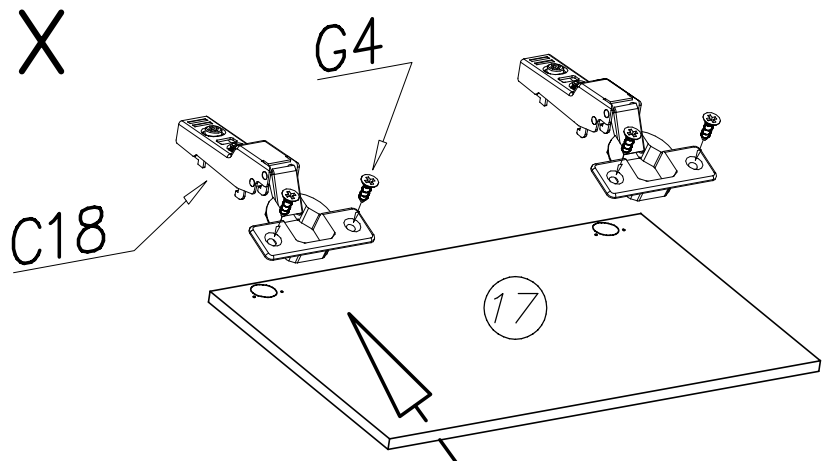

X

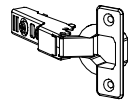

C18		G4	
Z35CP	x...(2)	4x16	x...(4)

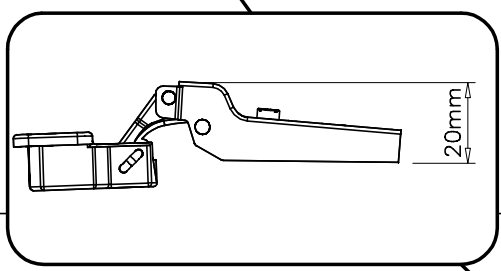
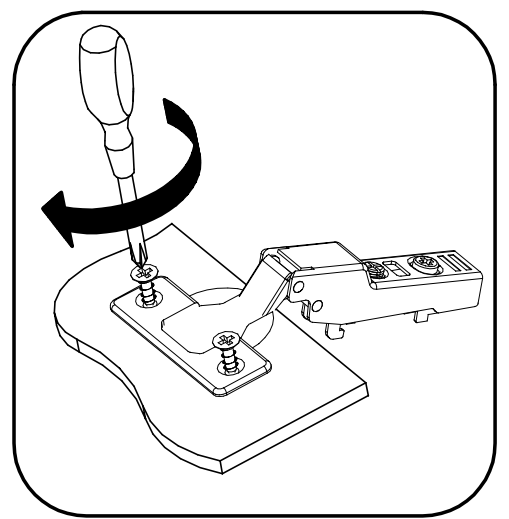

XI

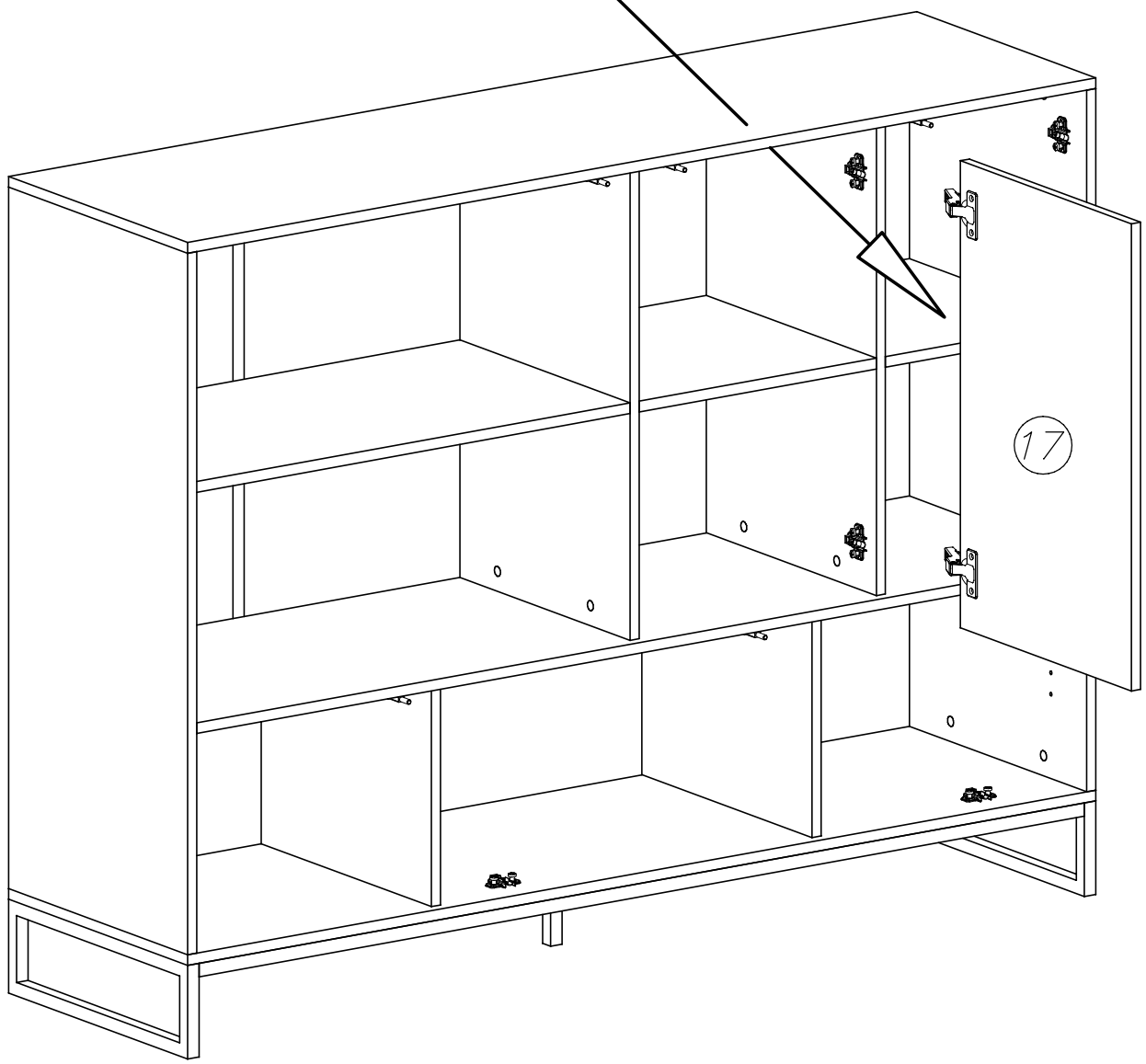

XII

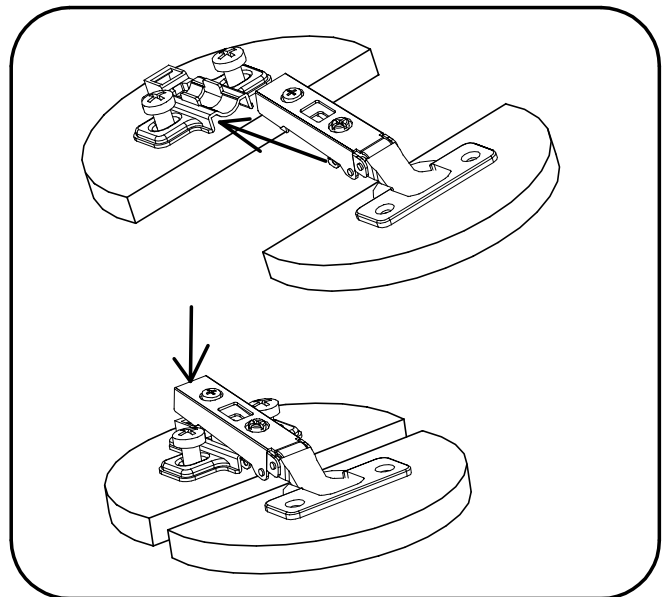
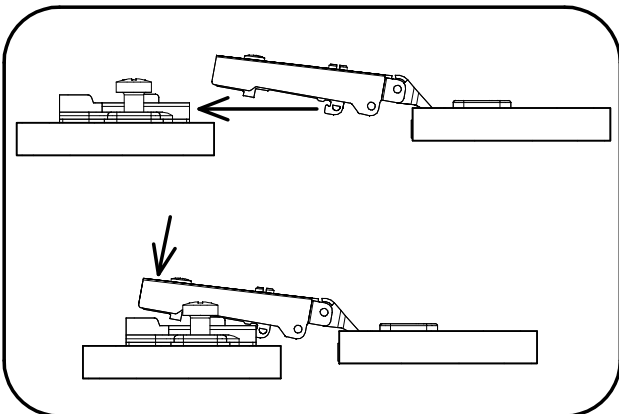
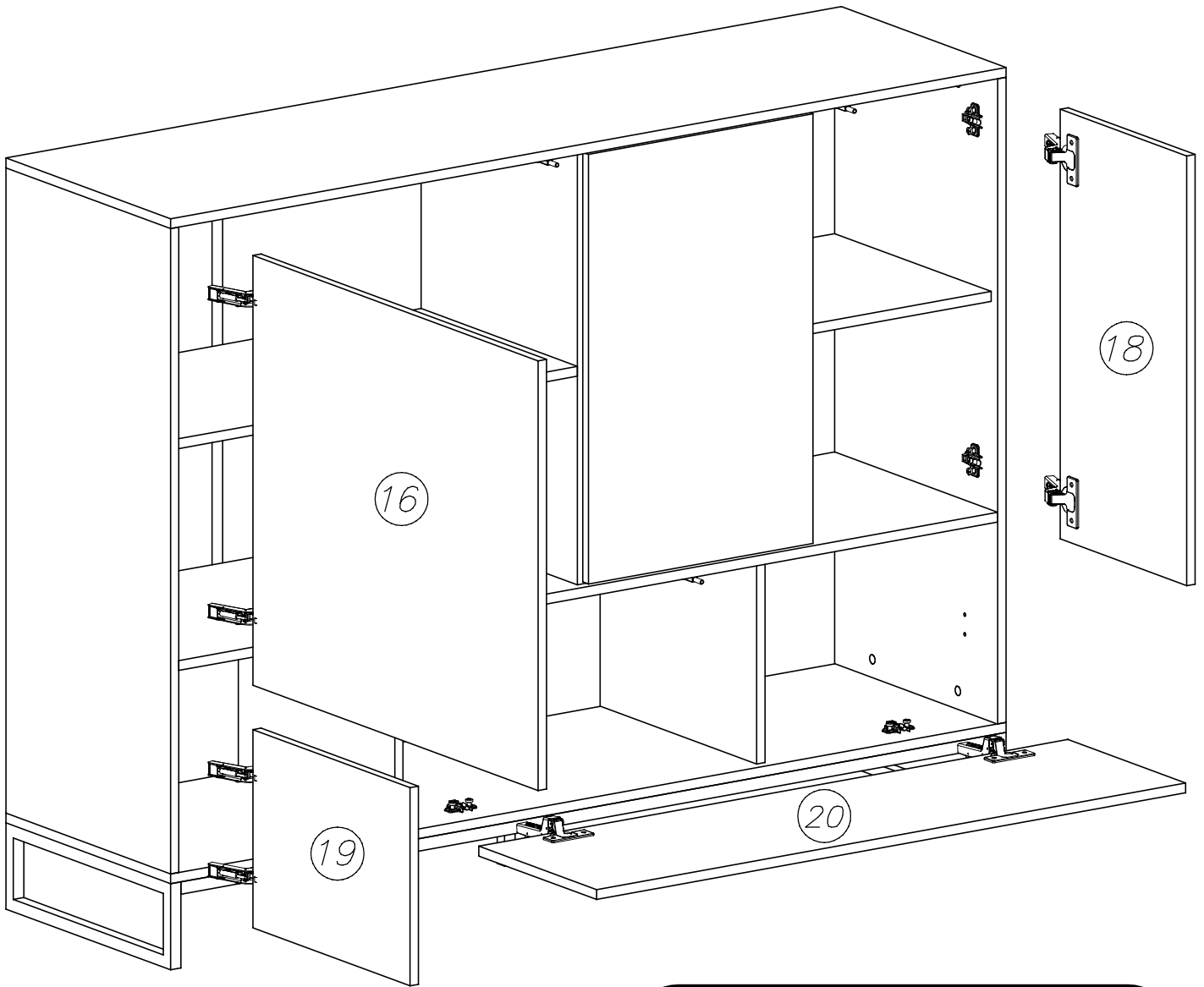
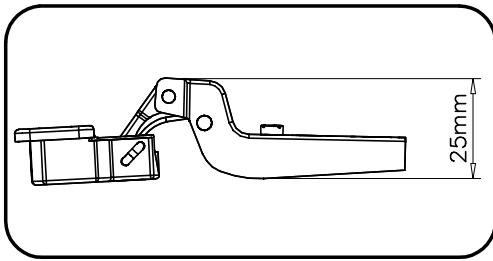

# XIII

